

4

3

2

1

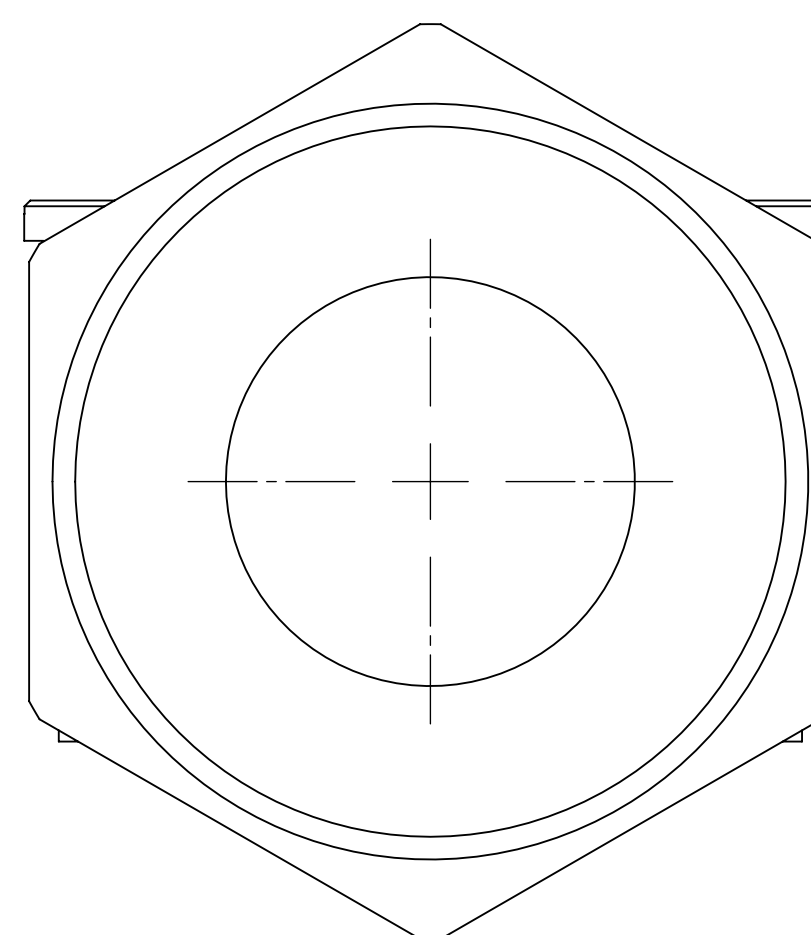
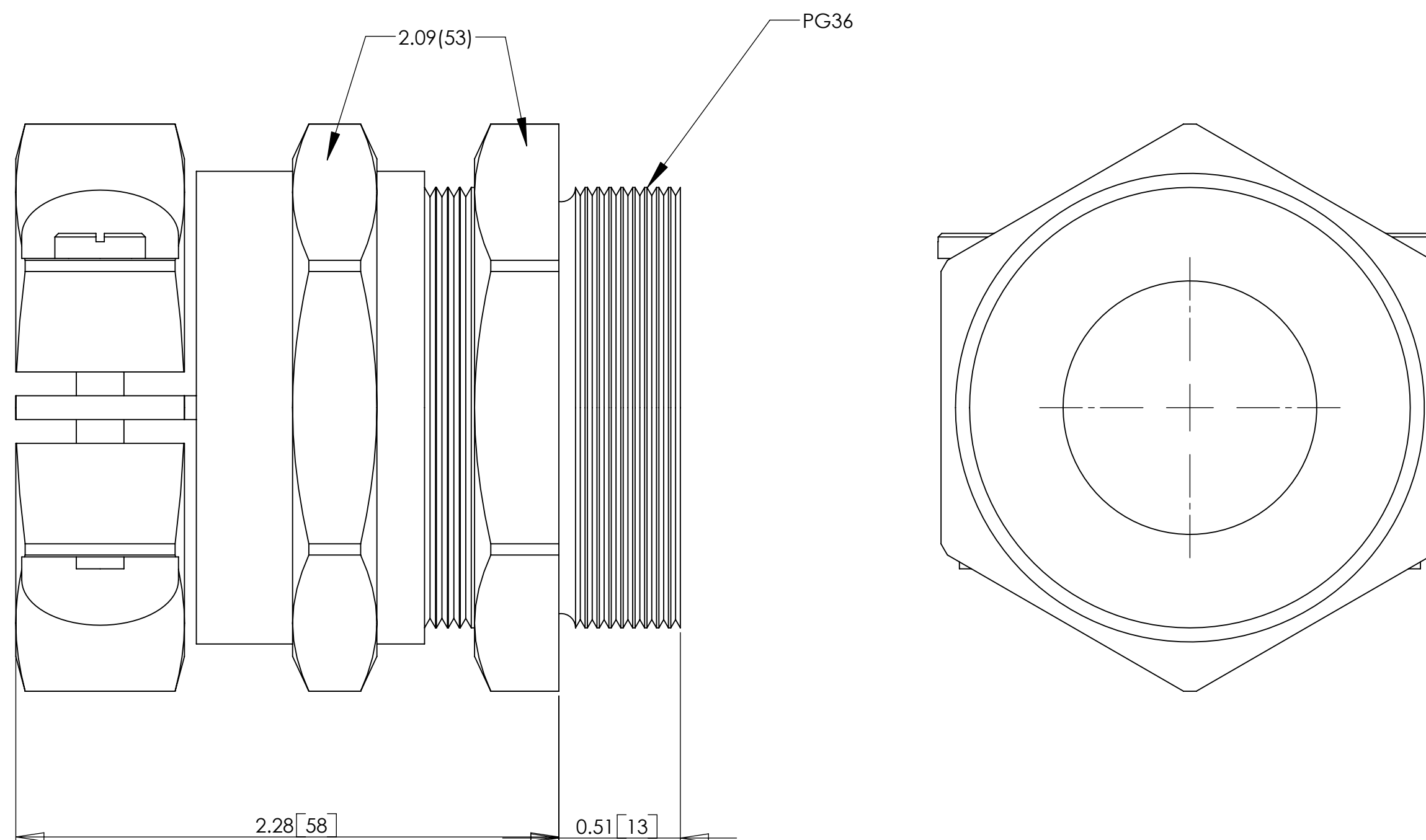
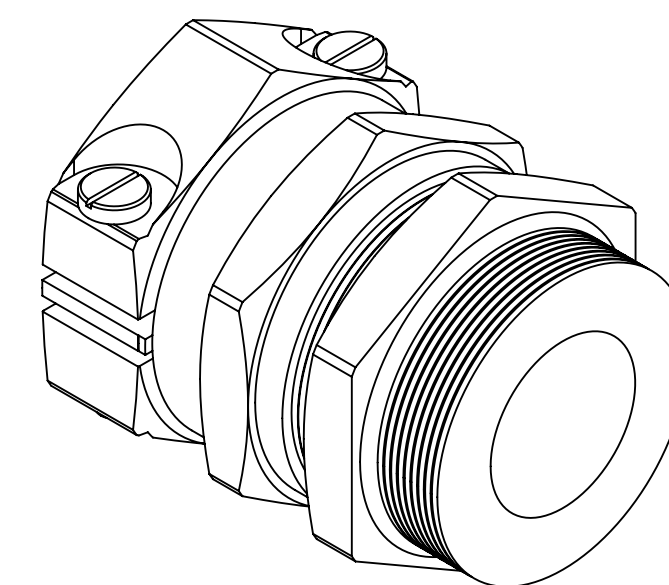

NOTES:

- 1) GENERAL DIMENSIONS DRAWINGS.
- 2) DIMENSIONS [] ARE IN INCHES.
- 3) DIMENSIONS NOTED ARE FOR REFERENCE ONLY.

Third angle projection

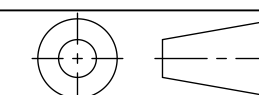

14853 E HINDSDALE AVE, SUITE d
 CENTENNAIL, CO 80112-4240, USA
 TEL: +1-303-699-1135
 TOLL FREE: +1-800-456-9012
 E MAIL: info@sealconusa.com,
 WEBSITE: WWW.SEALCONUSA.COM

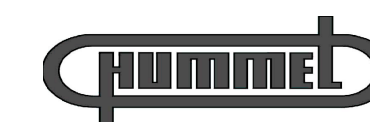

4

3

2

A

B

B

C

C

D

D

D