

Signal Connectors M 23

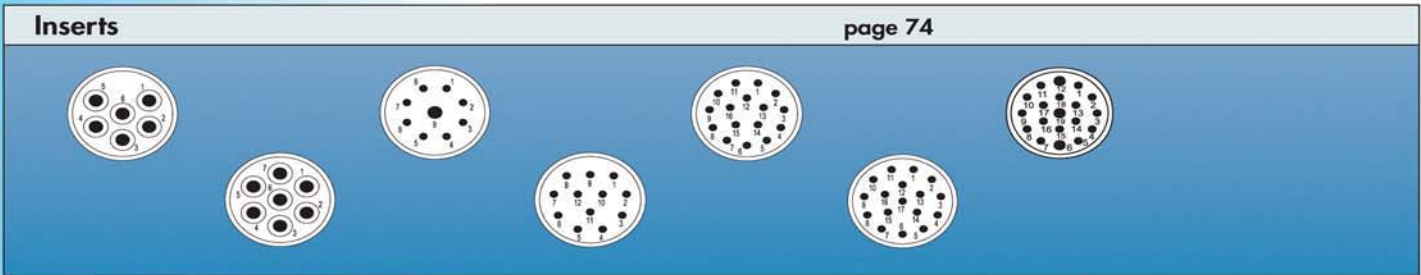

Product Overview



Technical Data

M 23 Signal Connectors

Mechanical Data	Materials and Technical Data
Housing	Copper-Zinc alloy Die Cast
Housing surface	Nickel plated other surface upon request
Inserts (for contacts)	Thermoplastic Polyamid PA 6 (Nylon 6/6), PBT Fire protection class V-0
Contacts	Brass Alloy
Contact surface at point of contact	Nickel and gold plated (0,25µm Au)
Minimum mating cycles	> 1000
Seals / O-Rings	Buna-N standard optional Viton® (Viton is a registered trademark of DuPont)
Temperature range	-40°C – 125°C (-40°F – 257°F)
Type of contacts	Crimp, solder, dip-solder (PCB)
Protection	IP 67 / IP 69K per EN 60529 (connected), NEMA 4x
Cable diameter range	3 – 17 mm (.12 – .67")

Electrical Data							
Number of positions	6	7	9 (8 + 1)	12	16	17	19 (16 + 3)
Number of contacts	6	7	8 1	12	16	17	16 3
Contact-Ø [mm]	2	2	1 2	1	1	1	1 1,5
Nominal current ¹⁾ [A]	20	20	8 20	8	8	8	8 10
Nominal voltage ²⁾ [V~] Degree of Protection 2 ³⁾	630	630	500	500	400	400	320
Nominal voltage ²⁾ [V~] Degree of Protection 3 ³⁾	300	300	200	200	160	160	100
Test voltage (Breakdown voltage) ⁴⁾ [V~]	2500	2500	2500	2500	1500	1500	1500
Insulation resistance [mΩ]	> 10 ¹⁰	> 10 ¹⁰	> 10 ¹⁰	> 10 ¹⁰	> 10 ⁶	> 10 ⁶	> 10 ⁶
Max. contact resistance [mΩ]	3	3	3	3	3	3	3

^{1), 2), 3), 4)} See Technical Informations page 14

Signal Connectors M 23 / Housing

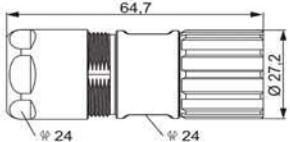
Straight Connector, Female Thread		Cable-Ø	Part Number
		3 – 7 mm (.12 – .28").....7.106.400.000	
		7 – 12 mm (.28 – .47").....7.106.500.000	
		11 – 17 mm (.44 – .67").....7.106.600.000	
		Contacts and inserts page 74 • Assembly instructions page 88	

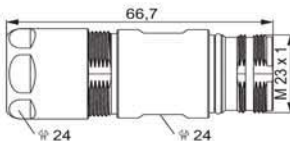
Straight Connector, Male Thread		Cable-Ø	Part Number
		3 – 7 mm (.12 – .28").....7.206.400.000	
		7 – 12 mm (.28 – .47").....7.206.500.000	
		11 – 17 mm (.44 – .67").....7.206.600.000	
		Contacts and inserts page 74 • Assembly instructions page 88	

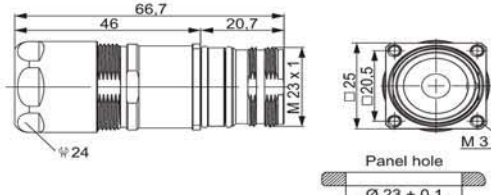
Panel Connector, Male Thread, with Strain Relief		Cable-Ø	Part Number
		4 threads M 3, rear mounting	
		3 – 7 mm (.12 – .28").....7.476.400.000	
		7 – 12 mm (.28 – .47").....7.476.500.000	
		11 – 17 mm (.44 – .67").....7.476.600.000	
		Optional: Flat gasket	
		Contacts and inserts page 74 • Assembly instructions page 88	

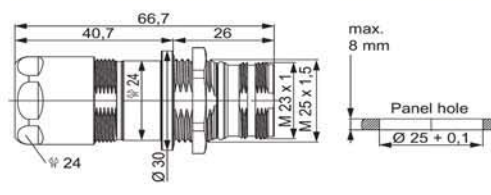
Panel Connector, Male Thread, with Strain Relief		Cable-Ø	Part Number
		Rear mounting, M 25 x 1,5 single hole mounted	
		3 – 7 mm (.12 – .28").....7.486.400.000	
		7 – 12 mm (.28 – .47").....7.486.500.000	
		11 – 17 mm (.44 – .67").....7.486.600.000	
		Including jam nut M 25 x 1,5	
		Contacts and inserts page 74 • Assembly instructions page 88	

Signal Connectors M 23 / Housing

Cable-Ø	Part Number	Right Angle Connector, Female Thread with positioning
3 – 7 mm (.12 – .28").....	7.300.300.000	
5 – 10 mm (.20 – .39").....	7.300.400.000	
7 – 12 mm (.28 – .47").....	7.300.500.000	
10 – 14 mm (.39 – .55").....	7.300.600.000	
<p>Contacts and inserts page 74 • Assembly instructions page 89</p>		

Cable-Ø	Part Number	Right Angle Connector, Female Thread, EMC with positioning
7 – 12 mm (.28 – .47").....	7.301.500.000	
11 – 17 mm (.43 – .67").....	7.301.600.000	
<p>Contacts and inserts page 74 • Assembly instructions page 89</p>		

Cable-Ø	Part Number	Right Angle Connector, EMC, rotating
7 – 12 mm (.28 – .47").....	7.306.500.000	
11 – 17 mm (.43 – .67").....	7.306.600.000	
<p>Contacts and inserts page 74 • Assembly instructions page 90</p>		

Cable-Ø	Part Number	Right Angle Connector, Male Thread
3 – 7 mm (.12 – .28").....	7.350.300.000	
5 – 10 mm (.20 – .39").....	7.350.400.000	
7 – 12 mm (.28 – .47").....	7.350.500.000	
10 – 14 mm (.39 – .55").....	7.350.600.000	
<p>Contacts and inserts page 74 • Assembly instructions page 89</p>		

Signal Connectors M 23 / Housing

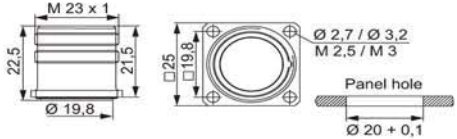
Panel Connector, Male Thread, Front Mounting		Type	Part Number
		4 holes \varnothing 3,2 mm (.13")	7.400.000.000
		4 threads M3	7.402.000.000
		4 holes \varnothing 2,7 mm (.11")	7.404.000.000
		4 threads M2,5	7.406.000.000
		Optional: Flat gasket	
Contacts and inserts page 74 • Assembly instructions page 91 / 92			

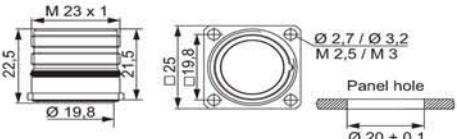
Panel Connector, Male Thread, Front Mounting		Type	Part Number
		With anti-vibration O-Ring	
		4 holes \varnothing 3,2 mm (.13")	7.410.000.000
		4 threads M3	7.412.000.000
		4 holes \varnothing 2,7 mm (.11")	7.414.000.000
		4 threads M2,5	7.416.000.000
		Optional: Flat gasket	
Contacts and inserts page 74 • Assembly instructions page 91 / 92			

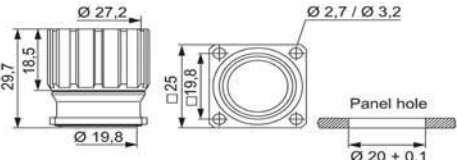
Panel Connector, Female Thread, with knurled Nut		Type	Part Number
		Without coding option	
		4 holes \varnothing 3,2 mm (.13")	7.440.000.000
		4 holes \varnothing 2,7 mm (.11")	7.444.000.000
		Optional: Flat gasket	
Contacts and inserts page 74 • Assembly instructions page 90			

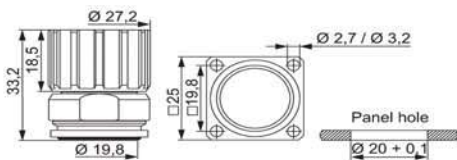
Panel Connector, Female Thread, with knurled Nut		Type	Part Number
		With coding option (8 x 45°)	
		4 holes \varnothing 3,2 mm (.13")	7.448.000.000
		4 holes \varnothing 2,7 mm (.11")	7.449.000.000
		Optional: Flat gasket	
Contacts and inserts page 74 • Assembly instructions page 90			







Signal Connectors M 23/ Housing

Type	Part Number	Panel Connector, Male Thread, Single Hole Mounted			
Front mounting for male inserts Thread M 20 x 1,57.420.000.000 Thread PG 13,57.422.000.000					
Optional: Flat gasket, jam nut M 20 x 1,5 / PG 13,5					
			M 20 x 1,5 / PG 13,5	PG 13,5: 20,6 + 0,1	M 20 x 1,5: 20,2 + 0,1
Contacts and inserts page 74 • Assembly instructions page 91					

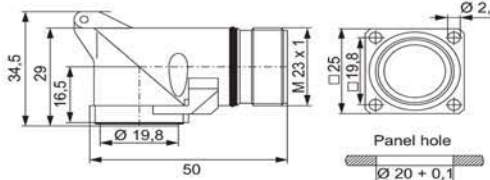
Type	Part Number	Panel Connector, Male Thread, Single Hole Mounted			
Front mounting for female inserts Thread M 20 x 1,57.421.000.000 Thread PG 13,57.423.000.000					
Optional: Flat gasket, jam nut M 20 x 1,5 / PG 13,5					
			M 20 x 1,5 / PG 13,5	PG 13,5: 20,6 + 0,1	M 20 x 1,5: 20,2 + 0,1
Contacts and inserts page 74 • Assembly instructions page 92					

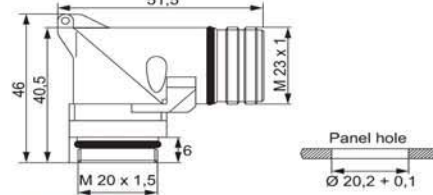
Type	Part Number	Panel Connector, Male Thread, Single Hole Mounted			
For insert with pins / sockets Thread M 25 x 1,57.425.000.000					
Optional: Flat gasket, jam nut M 25 x 1,5					
Contacts and inserts page 74 • Assembly instructions page 91 / 92					

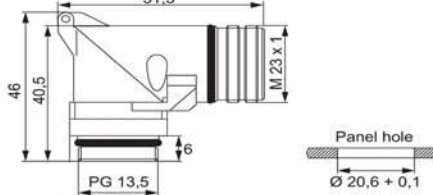
Signal Connectors M 23 / Housing

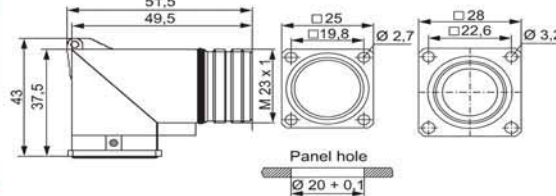
Right Angle Panel Connector, Male Thread		Type	Part Number
		4 holes 2,7 mm (.11").....	7.435.000.000
		Optional: Flat gasket	
		Easy fixation with M2,5 screws	
		Contacts and inserts page 74 • Assembly instructions page 93	
Right Angle Panel Connector, Male Thread, rotating		Type	Part Number
		335° rotating, hole mounted Thread M 20 x 1,5	7.431.000.000
		Contacts and inserts page 74 • Assembly instructions page 93	
Right Angle Panel Connector, Male Thread, rotating		Type	Part Number
		335° rotating, hole mounted Thread PG 13,5	7.432.000.000
		Contacts and inserts page 74 • Assembly instructions page 93	
Right Angle Panel Connector, Male Thread, rotating		Type	Part Number
		300° rotating, 1,5 mm locking screw at flange 4 x holes Ø 2,7 mm (.11") ..	7.433.000.000
		Flange 25 x 25 mm	
		4 x holes Ø 3,2 mm.....	7.433.100.000
		Flange 28 x 28 mm	
		Contacts and inserts page 74 • Assembly instructions page 93	

Signal Connectors M 23 / Housing





Type	Part Number	Panel Connector, Male Thread, Rear Mounting	
4 holes \varnothing 3,2 mm (.13")	7.450.000.000		
4 threads M 3	7.452.000.000		
4 holes \varnothing 2,7 mm (.11")	7.454.000.000		
4 threads M 2,5	7.456.000.000		
Optional: Flat gasket			
Contacts and inserts page 74 • Assembly instructions page 91 / 92			

Type	Part Number	Panel Connector, Male Thread, Rear Mounting	
With anti-vibration O-Ring			
4 holes \varnothing 3,2 mm (.13")	7.460.000.000		
4 threads M 3	7.462.000.000		
4 holes \varnothing 2,7 mm (.11")	7.464.000.000		
4 threads M 2,5	7.466.000.000		
Optional: Flat gasket			
Contacts and inserts page 74 • Assembly instructions page 91 / 92			

Type	Part Number	Panel Connector, Male Thread, Single Hole Mounted	
Rear mounting			
Thread M 25 x 1,5	7.458.000.000		
Including jam nut M 25 x 1,5			
Contacts and inserts page 74 • Assembly instructions page 91 / 92			

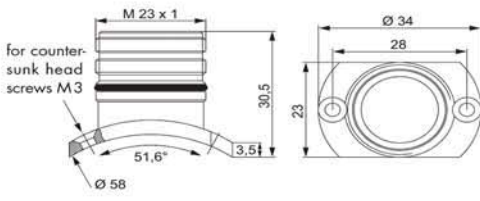
Type	Part Number	Panel Connector, Female Thread, Rear Mounting	
With knurled nut, rear mounting			
4 threads M 3	7.459.000.000		
Contacts and inserts page 74 • Assembly instructions page 90			

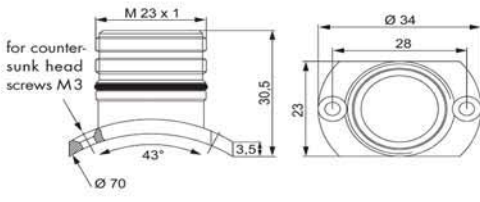
Signal Connectors M 23 / Housing

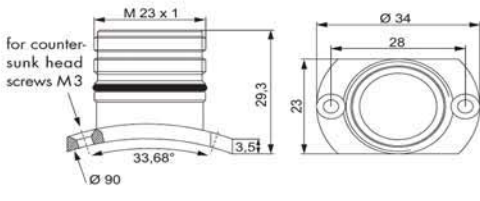
Panel Connector with Radius Flange		Type	Part Number
	 <p>for counter-sunk head screws M3</p>	With anti-vibration O-Ring and flat body gasket Ø 58 mm (2.28")7.490.000.000	
		Contacts and inserts page 74 • Assembly instructions page 91 / 92	
Panel Connector with Radius Flange		Type	Part Number
	 <p>for counter-sunk head screws M3</p>	With anti-vibration O-Ring and flat body gasket Ø 70 mm (2.76")7.491.000.000	
		Contacts and inserts page 74 • Assembly instructions page 91 / 92	
Panel Connector with Radius Flange		Type	Part Number
	 <p>for counter-sunk head screws M3</p>	With anti-vibration O-Ring and flat body gasket Ø 90 mm (3.54")7.492.000.000	
		Contacts and inserts page 74 • Assembly instructions page 91 / 92	

Signal Connectors M 23 / Housing

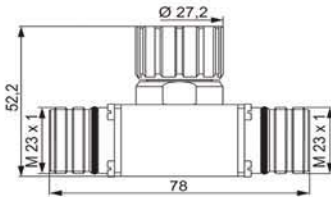
Type	Part Number	Signal Distribution
T 01	7.T01	
<p>Contacts and inserts page 74</p> 		

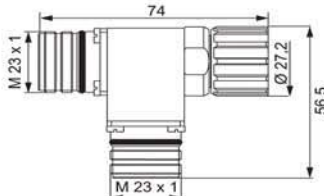

Type	Part Number	Signal Distribution
T 02	7.T02	
<p>Contacts and inserts page 74</p> 		

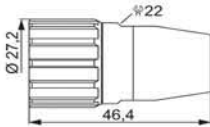
Signal Distribution	
<p>In case of so called Flying Connections it is often required to distribute, cross or combine signals. Depending on the requirements of the application, the connections can be supplied either as male or female connector, or they can be configured with strain relief fittings. There are many possible combinations, including the internal wiring, independent of their style, as T-, Y-, H-, or other special configurations.</p> 	

Type	Part Number	Bus End Connector
Closed type	7.105.000.000	
<p>Used to cap an open male connector in bus-systems</p> 		
<p>Contacts and inserts page 74</p>		

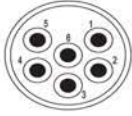
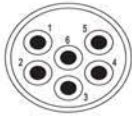
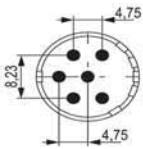
Signal Connectors M 23 / Inserts / Pinouts

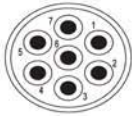
Inserts 6-pole	Type	Part Number	Part Number
 <p>Insert pin mating view (Part E)</p>  <p>Insert socket mating view (Part P)</p> 	Pinout clockwise	Pins	Sockets
	Insert with solder contacts	7.001.906.103	7.001.906.104
	Insert without contacts	7.003.906.101	7.003.906.102
	Insert with dip solder contacts		
	Length 3,5 mm	7.001.906.107	
	Insert with dip solder contacts		
	Length 10 mm	7.001.906.127	7.001.906.108
	Insert with dip solder contacts		
	Length 17 mm	7.001.906.137	7.001.906.118
		The correct dimension of a connector with dip solder contacts depends on the particular type of housing.	
	Contacts page 80 • Coding possibilities N, S, H, X and Y (see page 79)		

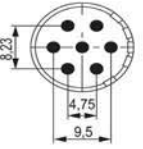
Inserts 7-pole	Type	Part Number	Part Number
 <p>Insert pin mating view (Part E)</p>  <p>Insert socket mating view (Part P)</p> 	Pinout clockwise	Pins	Sockets
	Insert with solder contacts	7.001.907.103	7.001.907.104
	Insert without contacts	7.003.907.101	7.003.907.102
	Insert with dip solder contacts		
	Length 3,5 mm	7.001.907.107	
	Insert with dip solder contacts		
	Length 10 mm	7.001.907.127	7.001.907.108
	Insert with dip solder contacts		
	Length 17 mm	7.001.907.137	7.001.907.118
		The correct dimension of a connector with dip solder contacts depends on the particular type of housing.	
	Contacts page 80 • Coding possibilities N, S, H, X and Y (see page 79)		

Signal Connectors M 23 / Inserts / Pinouts

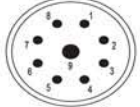
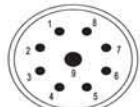
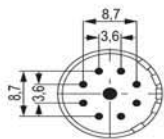
Type	Part Number	Part Number	Inserts 9-pole (8 + 1)
Pinout clockwise	Pins	Sockets	
Insert with solder contacts	7.001.981.103	7.001.981.104	 <p>Insert pin mating view (Part E)</p>
Insert without contacts	7.003.981.101	7.003.981.102	
Insert with dip solder contacts Length 3,5 mm	7.001.981.107		 <p>Insert socket mating view (Part P)</p>
Insert with dip solder contacts Length 10 mm	7.001.981.127	7.001.981.108	
Insert with dip solder contacts Length 17 mm	7.001.981.137	7.001.981.118	
<p>The correct dimension of a connector with dip solder contacts depends on the particular type of housing.</p>			
<p>Contacts page 80 • Coding possibilities N, S, H, X and Y (see page 79)</p>			

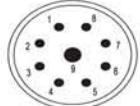
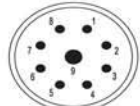
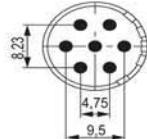
Type	Part Number	Part Number	Inserts 9-pole (8 + 1)
Pinout counter-clockwise	Pins	Sockets	
Insert with solder contacts	7.002.981.103	7.002.981.104	 <p>Insert pin mating view (Part P)</p>
Insert without contacts	7.004.981.101	7.004.981.102	
Insert with dip solder contacts Length 3,5 mm	7.002.981.107		 <p>Insert socket mating view (Part E)</p>
Insert with dip solder contacts Length 10 mm	7.002.981.127	7.002.981.108	
Insert with dip solder contacts Length 17 mm	7.002.981.137	7.002.981.118	
<p>The correct dimension of a connector with dip solder contacts depends on the particular type of housing.</p>			
<p>Contacts page 80 • Coding possibilities N, S, H, X and Y (see page 79)</p>			

Signal Connectors M23 / Inserts / Pinouts

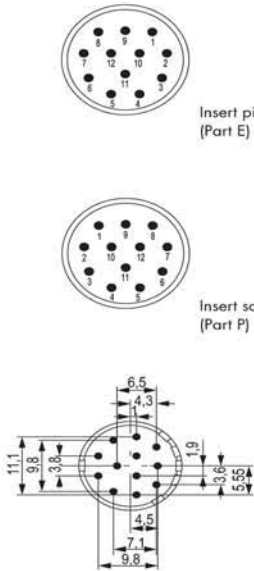
Inserts 12-pole	Type	Part Number	Part Number	
 <p>Insert pin mating view (Part E)</p> <p>Insert socket mating view (Part P)</p>	Pinout clockwise	Pins	Sockets	
	Insert with solder contacts	7.001.912.103	7.001.912.104	
	Insert with solder contacts +PE (Pos.9)	7.001.912.113	7.001.912.114	
	Insert without contacts	7.003.912.101	7.003.912.102	
	Insert without contacts +PE (Pos.9)	7.003.912.111	7.003.912.112	
	Insert with dip solder contacts Length 3,5 mm	7.001.912.107		
	Insert with dip solder contacts Length 10 mm	7.001.912.127	7.001.912.108	
	Insert with dip solder contacts Length 17 mm	7.001.912.137	7.001.912.118	
	<p>The correct dimension of a connector with dip solder contacts depends on the particular type of housing.</p>			
	<p>Contacts page 80 • Coding possibilities N, S, H, X and Y (see page 79)</p>			

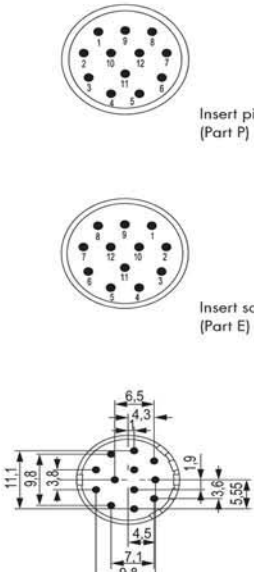
Inserts 12-pole	Type	Part Number	Part Number	
 <p>Insert pin mating view (Part P)</p> <p>Insert socket mating view (Part E)</p>	Pinout counter-clockwise	Pins	Sockets	
	Insert with solder contacts	7.002.912.103	7.002.912.104	
	Insert with solder contacts +PE (Pos.9)	7.002.912.113	7.002.912.114	
	Insert without contacts	7.004.912.101	7.004.912.102	
	Insert without contacts +PE (Pos.9)	7.004.912.111	7.004.912.112	
	Insert with dip solder contacts Length 3,5 mm	7.002.912.107		
	Insert with dip solder contacts Length 10 mm	7.002.912.127	7.002.912.108	
	Insert with dip solder contacts Length 17 mm	7.002.912.137	7.002.912.118	
	<p>The correct dimension of a connector with dip solder contacts depends on the particular type of housing.</p>			
	<p>Contacts page 80 • Coding possibilities N, S, H, X and Y (see page 79)</p>			

Signal Connectors M23 / Inserts / Pinouts

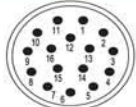
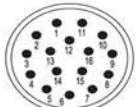
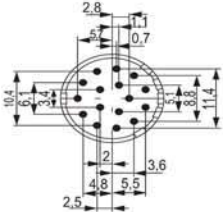
Type	Part Number	Part Number	Inserts 16-pole
Pinout clockwise	Pins	Sockets	
Insert with solder contacts	7.001.916.103	7.001.916.104	 <p>Insert pin mating view (Part E)</p>
Insert without contacts	7.003.916.101	7.003.916.102	
Insert with dip solder contacts Length 3,5 mm	7.001.916.107		 <p>Insert socket mating view (Part P)</p>
Insert with dip solder contacts Length 10 mm	7.001.916.127	7.001.916.108	
Insert with dip solder contacts Length 17 mm	7.001.916.137	7.001.916.118	
<p>The correct dimension of a connector with dip solder contacts depends on the particular type of housing.</p>			
			
<p>Contacts page 80 • Coding possibilities N, S, H, X and Y (see page 79)</p>			

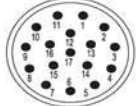
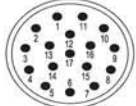
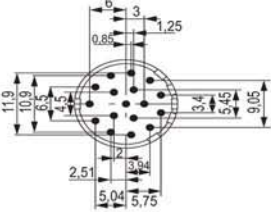
Type	Part Number	Part Number	Inserts 17-pole
Pinout clockwise	Pins	Sockets	
Insert with solder contacts	7.001.917.103	7.001.917.104	 <p>Insert pin mating view (Part E)</p>
Insert without contacts	7.003.917.101	7.003.917.102	
Insert with dip solder contacts Length 3,5 mm	7.001.917.107		 <p>Insert socket mating view (Part P)</p>
Insert with dip solder contacts Length 10 mm	7.001.917.127	7.001.917.108	
Insert with dip solder contacts Length 17 mm	7.001.917.137	7.001.917.118	
<p>The correct dimension of a connector with dip solder contacts depends on the particular type of housing.</p>			
			
<p>Contacts page 80 • Coding possibilities N, S, H, X and Y (see page 79)</p>			

Signal Connectors M 23 / Inserts / Pinouts

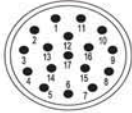
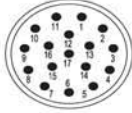
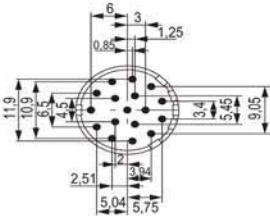
Inserts 17-pole	Type	Part Number	Part Number	
 <p>Insert pin mating view (Part P)</p>  <p>Insert socket mating view (Part E)</p> 	Pinout counter-clockwise	Pins	Sockets	
	Insert with solder contacts7.002.917.1037.002.917.104	
	Insert without contacts7.004.917.1017.004.917.102	
	Insert with dip solder contacts Length 3,5 mm7.002.917.107		
	Insert with dip solder contacts Length 10 mm7.002.917.1277.002.917.108	
	Insert with dip solder contacts Length 17 mm7.002.917.1377.002.917.118	
	The correct dimension of a connector with dip solder contacts depends on the particular type of housing.			
	Contacts page 80 • Coding possibilities N, S, H, X and Y (see page 79)			

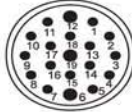
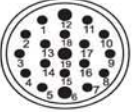
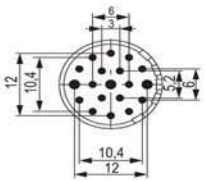
Inserts 19-pole	Type	Part Number	Part Number
 <p>Insert pin mating view (Part E)</p>  <p>Insert socket mating view (Part P)</p> 	Pinout clockwise	Pins	Sockets
	Insert with solder contacts7.001.919.1037.001.919.104
	Insert with solder contacts +PE (Pos. 12)7.001.919.1137.001.919.114
	Insert with solder contacts + PE (Pos. 12) 1,5 mm elongated7.001.919.123	
	Insert without contacts7.003.919.1017.003.919.102
	Insert without contacts +PE (Pos. 12)7.003.919.1117.003.919.112
	Insert with dip solder contacts Length 3,5 mm7.001.919.107	
	Insert with dip solder contacts Length 10 mm7.001.919.1277.001.919.108
	Insert with dip solder contacts Length 17 mm7.001.919.1377.001.919.118
	The correct dimension of a connector with dip solder contacts depends on the particular type of housing.		
Contacts page 80 • Coding possibilities N, S, H, X and Y (see page 79)			

Signal Connectors M 23 / Required Contacts









Number of Poles	Required Contacts	Contact Arrangement
6	6 x 2 mm	
7	7 x 2 mm	
9 (8 + 1)	8 x 1 mm 1 x 2 mm	
12	12 x 1 mm	
16	16 x 1 mm	
17	17 x 1 mm	
19	16 x 1 mm 3 x 1,5 mm	

Crimp contacts page 80





Number of Poles	Coding Possibilities	Coding
6-pole	N, S, H, X, Y and Z	<p>Female Inserts mating view</p>
7-pole	N, S, H, X and Y	
9-pole	N, S, H, X and Y	<p>Male Inserts mating view</p>
12-pole	N, S, H, X, Y and Z	
16-pole	N, S, H, X, Y and Z	
17-pole	N, S, H, X, Y and Z	
19-pole	N, S, H, X and Y	

As standard, coding groove N is opened. To use other codings, please remove the coding barrier.

Signal Connectors M23 / Contacts

Contacts	Type	Crimp Range	Part Number
	Crimp pin 1 mm, machined0,08 – 0,56 mm ² (AWG 28 – 20)	.7.010.901.031
	Crimp pin 1 mm, machined0,14 – 1 mm ² (AWG 26 – 17)7.010.901.001
	Crimppin 1 mm, machined0,75 – 1,5 mm ² (AWG 17 – 16)	..7.010.901.021
	Crimp socket 1 mm, machined	...0,08 – 0,56 mm ² (AWG 28 – 20)	..7.010.901.012
	Crimp socket 1 mm, machined	...0,34 – 1 mm ² (AWG 22 – 17)7.010.901.002
	Crimp socket 1 mm, machined	...0,75 – 1,5 mm ² (AWG 17 – 16)	..7.010.901.022
	Crimp pin 1 mm, stamped0,14 – 0,56 mm ² (AWG 26 – 20)	..upon request
	Crimp socket 1 mm, stamped0,14 – 0,56 mm ² (AWG 26 – 20)	..upon request
	Crimp pin 1,5 mm, machined0,14 – 1 mm ² (AWG 26 – 17)7.010.901.501

Signal Connectors M23 / Contacts



Type	Crimp Range	Part Number	Contacts
Crimp socket 1,5 mm, machined..	0,14 – 0,56 mm ² (AWG 26 – 20)	..7.010.901.512	
Crimp socket 1,5 mm, machined..	0,56 – 1 mm ² (AWG 20 – 17)7.010.901.502	
Crimp pin 2 mm, machined	0,75 – 2,5 mm ² (AWG 18 – 14)	..7.010.902.001	
Crimp socket 2 mm, machined ...	0,75 – 2,5 mm ² (AWG 18 – 14)	..7.010.902.002	

Crimp Tool Settings see page 86

Signal Connector / Accessories



Accessories	Type	Part Number
	Plastic protective cap for connectors with male thread	7.000.900.101
	for connectors with female thread	7.000.900.102
	Brass protective cap for connectors with female thread	7.010.900.103
	Brass protective cap for connectors with male thread	7.010.900.102
	Brass protective cap with chain for connectors with female thread	Length 70 mm7.010.9S0.703
		Length 100 mm7.010.9S1.003
	Brass protective cap with chain for connectors with male thread	Length 70 mm7.010.9S0.702
		Length 100 mm7.010.9S1.002
	Assembly tool	7.010.900.101

Signal Connector / Accessories

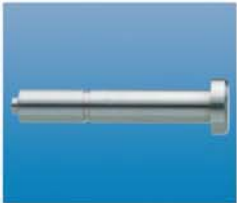
Type	Part Number	Accessories
Crimp tool for manual crimping of machined crimp contacts for signal connectors	7.000.900.904	
Operating instructions on page 84 - 86, 94		
Adaptor flange for Straight Connectors	7.010.900.128	
Adapter for Conduit Fittings	Snapflex 16.....7.010.900.204 DN 127.010.900.205 Snapflex 20.....7.010.900.206 DN 147.010.900.207 Snapflex 25.....7.010.900.208 DN 177.010.900.209	

Type	Part Number	for HUMMEL Contact	Locator
Locator for Crimp Tool DMC M22520 with positioner	7.000.9DM.C03	7.010.901.001, 7.010.901.501, 7.010.902.001	
Locator for Crimp Tool DMC M22520 with positioner	7.000.9DM.C04	7.010.901.012, 7.010.901.002, 7.010.901.512, 7.010.901.502, 7.010.902.002	

Crimp Tool for Signal Connectors M23 / M16

Crimp Tool	Type	Part Number
	<p>Crimp tool.....7.000.900.904 / 7.000.900.907</p> <p>Application The four indent crimp tool 7.000.900.904 / 7.000.900.907 has been developed for optimal crimping of machined contacts with diameters from 0.08 to 2.5 mm² (28 through 14 AWG).</p> <p>How to Crimp The reference table indicates the correct locator position to be selected and the crimp depth to be adjusted for the contact to be crimped. The contact is then inserted through the access hole of the tool on the opposite side of the locator. The contact is held in place by closing the handles to the first lock-in position thus preventing the contact from falling out of the tool and facilitating insertion of the wire into the contact. The precision ratchet assures consistently accurate crimping every time by forcing the tool to be closed all the way completing the crimping cycle before the tool can be opened again.</p> <p>Exchange of the Locator The locator can be exchanged by removing the socket head cap screw with a socket wrench. It can then be disassembled from the hex head screw by turning it counter-clockwise.</p>	 <p>Crimp jaws</p> <p>Adjusting screw with 0.01 mm increments</p> <p>Scale indicating 0.2 mm increments</p> <p>Physical stop</p>

Crimp Tool for Signal Connectors M 23 / M 16

Crimp Tool

Adjustment of Crimp Depth

Crimp depth can be adjusted as follows:

Turn the adjusting screw clockwise for reducing the crimp depth and counter-clockwise for increasing the crimp depth.

Adjustment Increments:

- 1 space on the adjusting screw $\hat{=}$ adjustment by 0.01 mm
- 1 full rotation of adjusting screw $\hat{=}$ adjustment by 0.2 mm (indication on the screw as well as on the rough scale)
- 5 rotations of the adjusting screw $\hat{=}$ adjustment by 1 mm (indication on the scale)

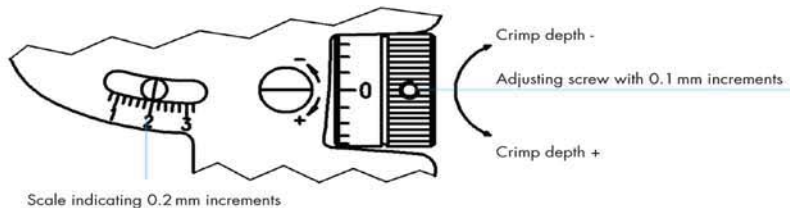

Control of Crimp Depth

Crimp tool adjustment is done at the factory, but with frequent use, periodic calibration is recommended to insure accuracy. This is easily accomplished with a 1.0 mm \varnothing wire gauge as follows.

A crimp depth of 1.0 mm is set by means of the adjusting screw (scale mark at „1“, screw mark at „0“ as shown in the fig. above) and the tool in the closed position. After insertion of the gauge, there must be just enough space for moving the gauge inside the entry hole. If the opening is too small or too large to exactly match the gauge, the deviation (+/-) can be checked by the precision setting of the screw. Please contact the factory in case the deviation exceeds the tolerances specified by the contract manufacturer.

Maintenance and Repair

Keep the tool clean and properly stored when not in service. All pivot points need to be oiled regularly and the spring clips securing the bolts have to always be in place. For repair please send the tool back to the factory.

Crimp Tool for Signal Connectors M 23

Crimp Tool Setting for HUMMEL Crimp Contacts (Crimp Tool 7.000.900.904)					
Part Number	Crimp Contact	Cross Section (mm ²)	AWG	Crimp Tool Setting mm	Locator Setting
7.010.901.001	Crimp pin 1 mm	0,14	AWG 26	0,70	1
		0,25	AWG 24	0,76	
		0,34	AWG 22	0,82	
		0,50	AWG 20	0,90	
		0,75	AWG 18	1,00	
		1,00	AWG 17	1,10	
7.010.901.012	Crimp socket 1 mm (0,08 – 0,56 mm ²)	0,08	AWG 28	0,75	2
		0,14	AWG 26	0,78	
		0,25	AWG 24	0,82	
		0,34	AWG 22	0,86	
		0,56	AWG 20	0,90	
7.010.901.002	Crimp socket 1 mm (0,34 – 1 mm ²)	0,34	AWG 22	0,77	2
		0,56	AWG 20	0,82	
		0,75	AWG 18	0,88	
		1,00	AWG 17	0,95	
7.010.901.501	Crimp pin 1,5 mm	0,14	AWG 26	0,65	3
		0,25	AWG 24	0,68	
		0,34	AWG 22	0,72	
		0,56	AWG 20	0,81	
		0,75	AWG 18	0,95	
		1,00	AWG 17	1,07	
7.010.901.512	Crimp socket 1,5 mm (0,14 – 0,56 mm ²)	0,14	AWG 26	0,70	2
		0,25	AWG 24	0,73	
		0,34	AWG 22	0,77	
		0,56	AWG 20	0,85	
7.010.901.502	Crimp socket 1,5 mm (0,34 – 1 mm ²)	0,34	AWG 22	0,88	2
		0,56	AWG 20	0,95	
		0,75	AWG 18	1,05	
		1,0	AWG 17	1,13	
7.010.902.001	Crimp pin 2 mm	0,75	AWG 18	1,25	4
		1,0	AWG 17	1,35	
		1,5	AWG 16	1,45	
		2,5	AWG 14	1,60	
7.010.902.002	Crimp socket 2 mm	0,75	AWG 18	1,25	5
		1,0	AWG 17	1,35	
		1,5	AWG 16	1,45	
		2,5	AWG 14	1,60	

Assembly information see page 94

Crimp Tool for Signal Connectors M23

Crimp Tool Setting for HUMMEL Crimp Contacts (Crimp Tool 7.000.900.904)					
Part Number	Crimp Contact	Cross Section (mm ²)	AWG	Crimp Tool Setting mm	Locator Setting
7.010.901.031	Crimp pin 1 mm	0,08		0,72	1
		0,14		0,78	
		0,25		0,82	
		0,34		0,86	
		0,56		0,90	
7.010.901.021	Crimp pin 1 mm	0,75		0,80	1
		1,00		0,86	
		1,50		0,95	
7.010.901.022	Crimp socket 1 mm	0,75		0,80	2
		1,00		0,86	
		1,50		0,95	

Signal Connectors M23 / Assembly Instructions

Straight Connector, Male / Female Thread

-
-
-
-
-
-
-
-

Signal Connectors M 23 / Assembly Instructions

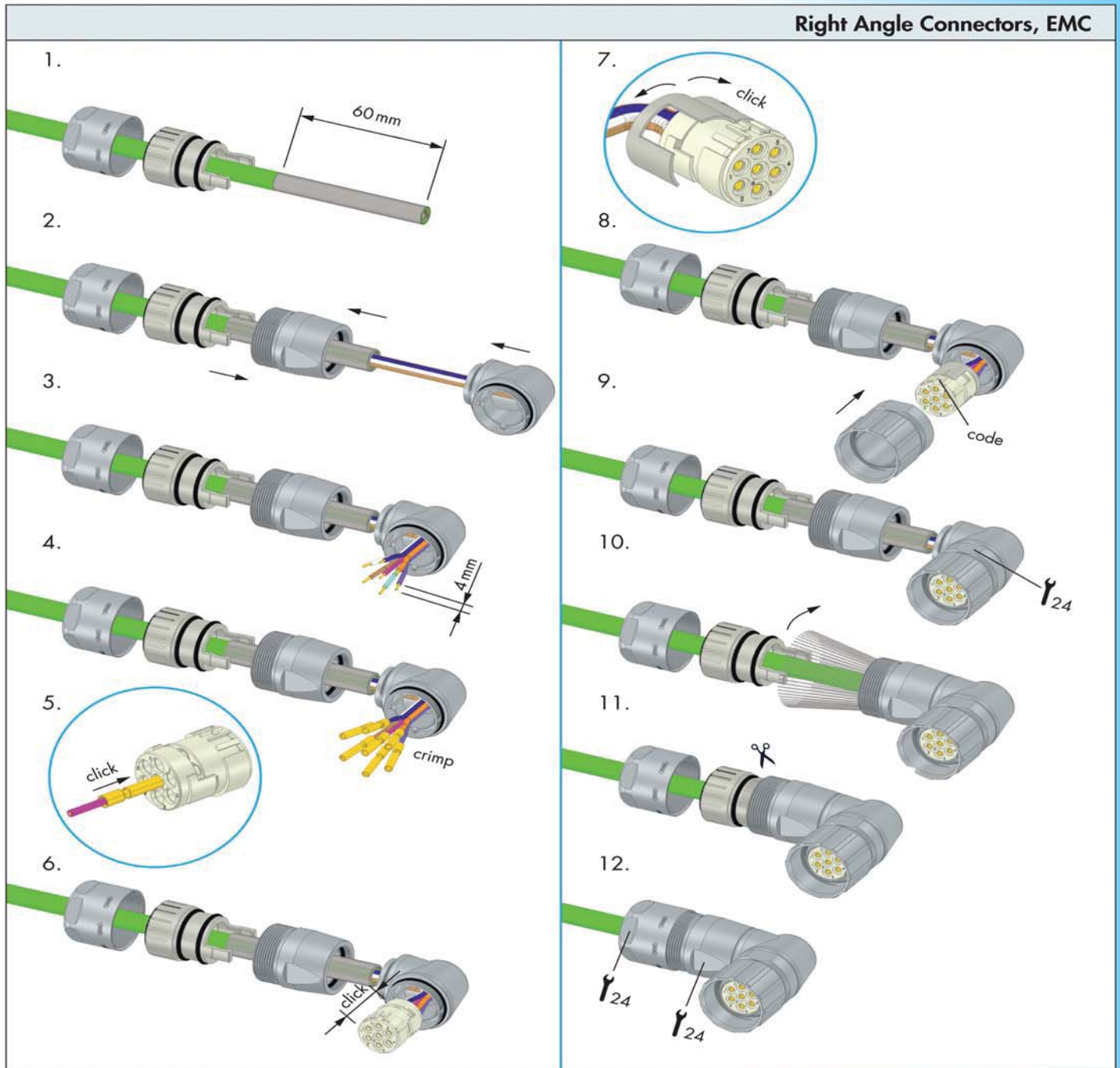

Signal Connectors M 23 / Assembly Instructions

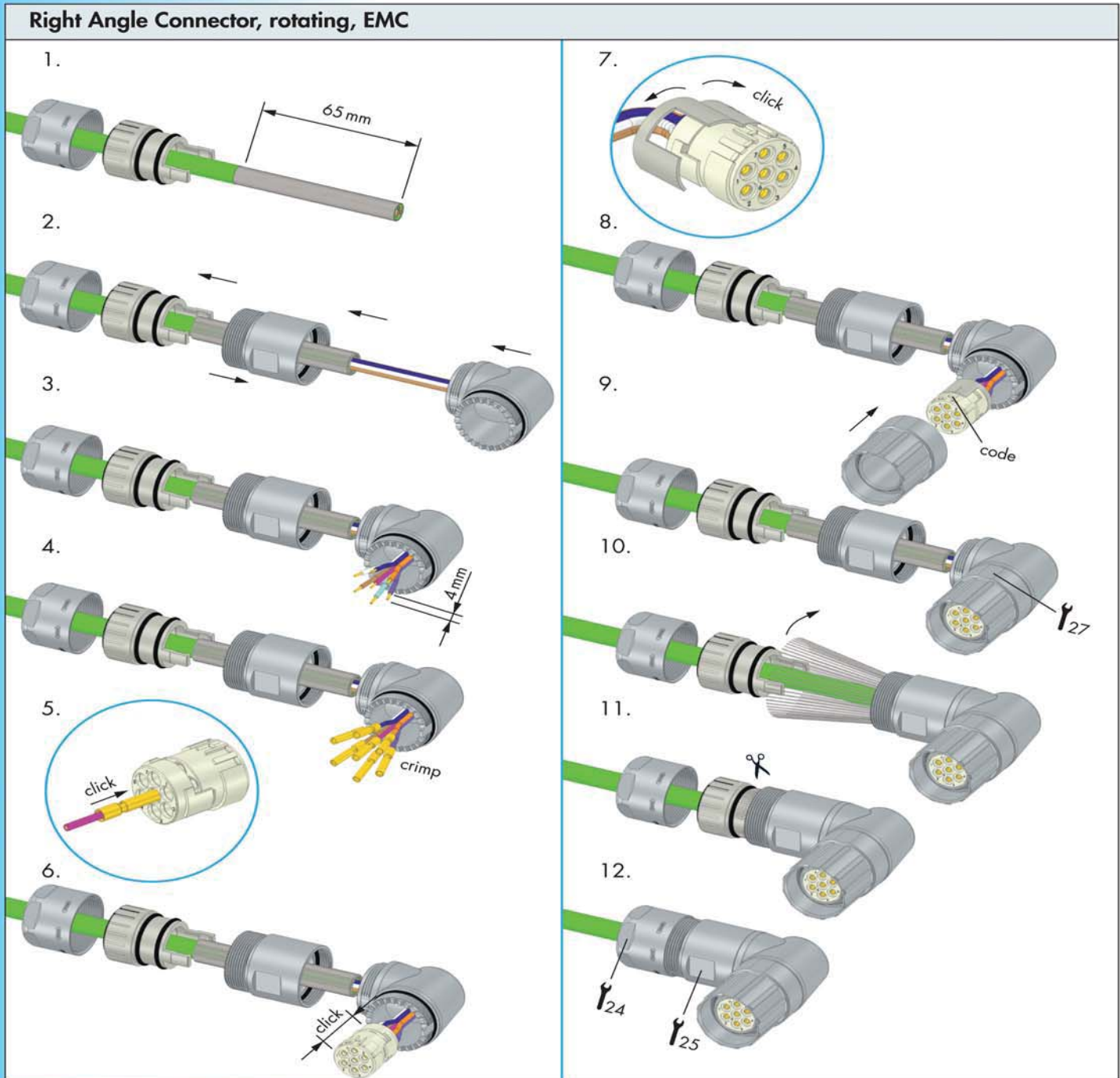

Signal Connectors M 23 / Assembly Instructions

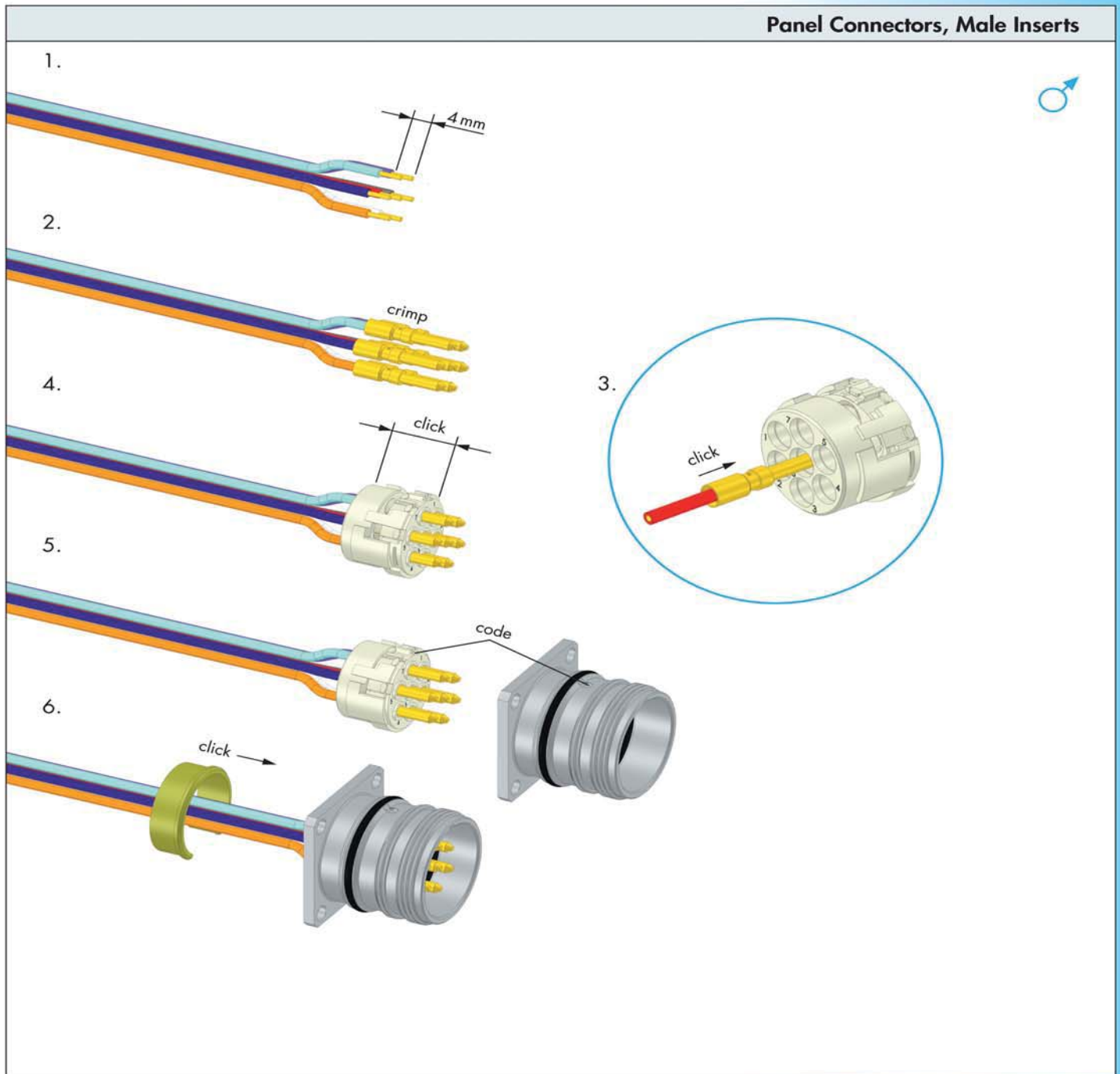

Signal Connectors M23 / Assembly Instructions

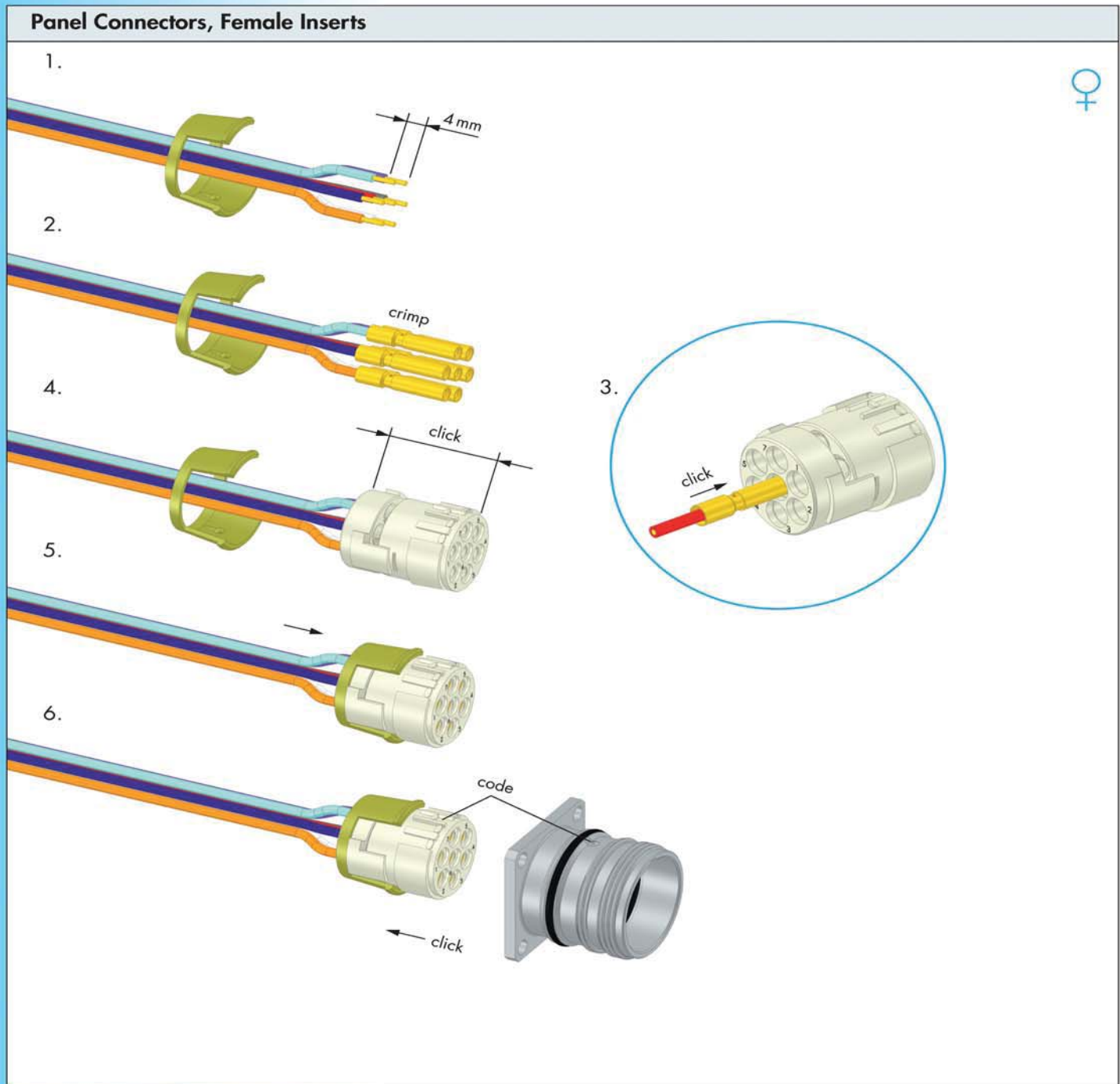

Signal Connectors M 23 / Assembly Instructions

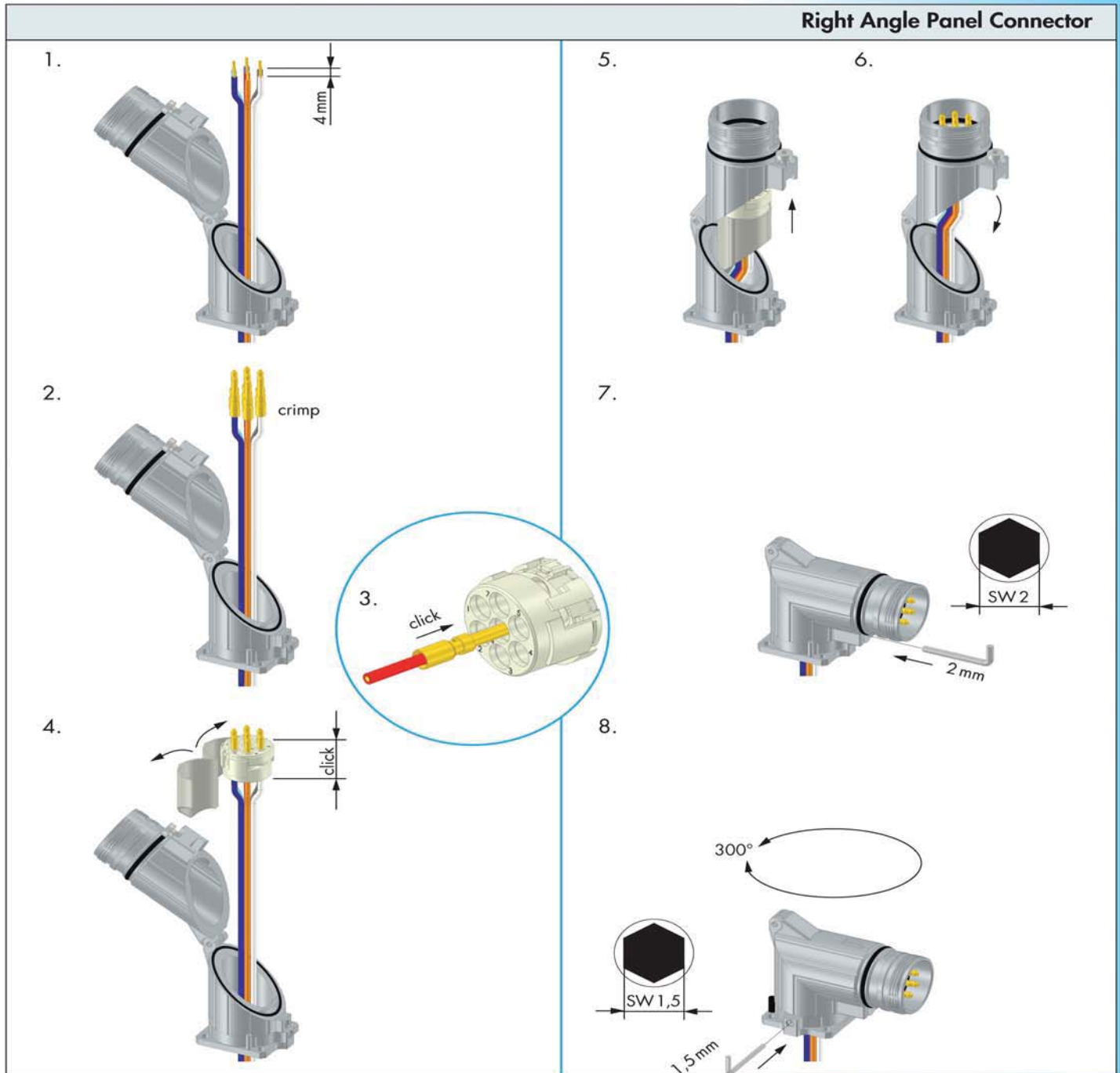

Crimping, Assembly and Disassembly of Contacts

Crimping, Assembly and Disassembly of Contacts

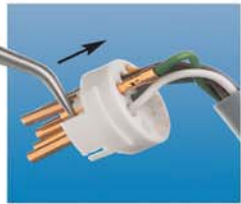

Crimping

- Remove conductor insulation 4 mm (.16") max.
- Select appropriate Crimp tool setting (see page 86)
- Insert Crimp contact into the positioner of the tool
- Insert stripped end of conductor into the crimp opening of the contact
- Squeeze handles of crimp tool together

Assembly

- Open crimping jaws and remove contact
- Pry open upper and lower insert approx. 3 mm (1/8") apart as shown
- Insert the contact and conductor assembly into the desired location
- Press upper and lower insert parts together

Disassembly

No special tools are needed to remove the crimp contacts from the insert.

- Remove upper part of insert
- With a pair of needle nose pliers, wiggle the contact and push it back through the lower part of insert
- Insert contacts into new location and push until it snaps in position
- Align the nose and groove of the upper and lower part of insert and press together

Shielding

- Assemble strain relief insert with insert
- Fold stranding of the shield back over the first O-Ring of the strain relief insert
- Cut back the overextending braid



The stranding of the shield is not allowed to touch the second O-Ring. Otherwise the assembly may not be proof.