

PART NUMBERS	THREAD TYPE AND SIZE	(G) THICKNESS INCHES (METRIC)	(H) THICKNESS INCHES (METRIC)
NM-75-XL	<b>M75 X 1.5</b>	.32 (8)	3.35 (85)
NM-80-XL	<b>M80 X 2</b>	.32 (8)	3.54 (90)
NM-90-XL	<b>M90 X 2</b>	.32 (8)	3.94 (100)
NM-10-XL	<b>M100 X 2</b>	.43 (11)	4.53 (115)
NM-11-XL	<b>M110 X 2</b>	.43 (11)	4.92 (125)

PART NUMBERS	CABLE RANGE	THREAD TYPE & SIZE	HOLE DIAMETER	BODY LENGTH	THREAD LENGTH	WRENCHING FLAT
CX10MA-BR	2.87-3.15 (73-80 mm)	M100 X 2	3.94 (100 mm)	2.05 (52 mm)	.79 (20 mm)	4.33 (110 mm)
CX10MB-BR	3.07-3.35 (78-85 mm)	M100 X 2	3.94 (100 mm)	2.05 (52 mm)	.79 (20 mm)	4.33 (110 mm)
CX11MA-BR	3.27-3.54 (83-90 mm)	M110 X 2	4.33 (110 mm)	2.05 (52 mm)	.79 (20 mm)	4.72 (120 mm)
CX75MA-BR	1.89-2.17 (48-55 mm)	M75 X 1.5	2.95 (75 mm)	1.65 (42 mm)	.59 (15 mm)	3.15 (80 mm)
CX75MB-BR	2.09-2.36 (53-60 mm)	M75 X 1.5	2.95 (75 mm)	1.65 (42 mm)	.59 (15 mm)	3.35 (85 mm)
CX80MA-BR	2.28-2.56 (58-65 mm)	M80 X 2	3.15 (80 mm)	1.65 (42 mm)	.59 (15 mm)	3.54 (90 mm)
CX90MA-BR	2.48-2.76 (63-70 mm)	M90 X 2	3.54 (90 mm)	1.65 (42 mm)	.59 (15 mm)	3.94 (100 mm)
CX90MB-BR	2.68-2.95 (68-75 mm)	M90 X 2	3.54 (90 mm)	2.05 (52 mm)	.59 (15 mm)	3.94 (100 mm)

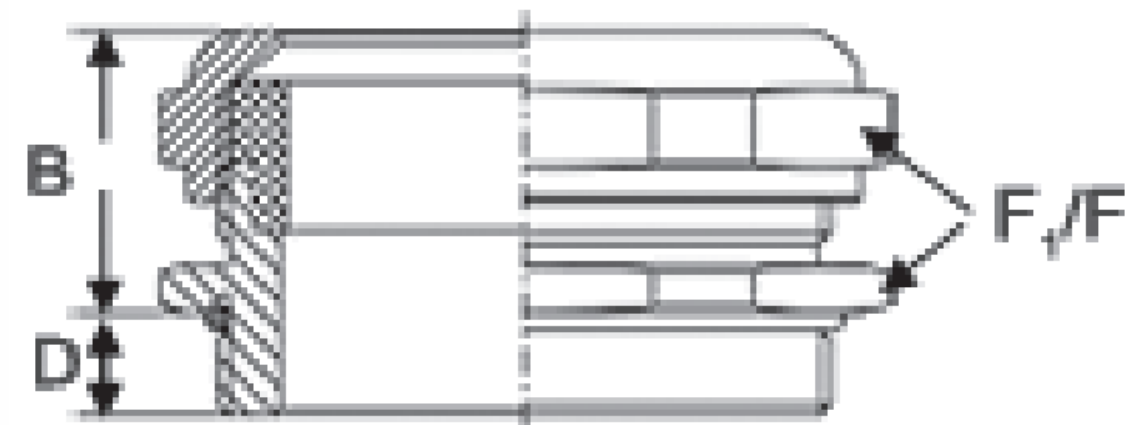
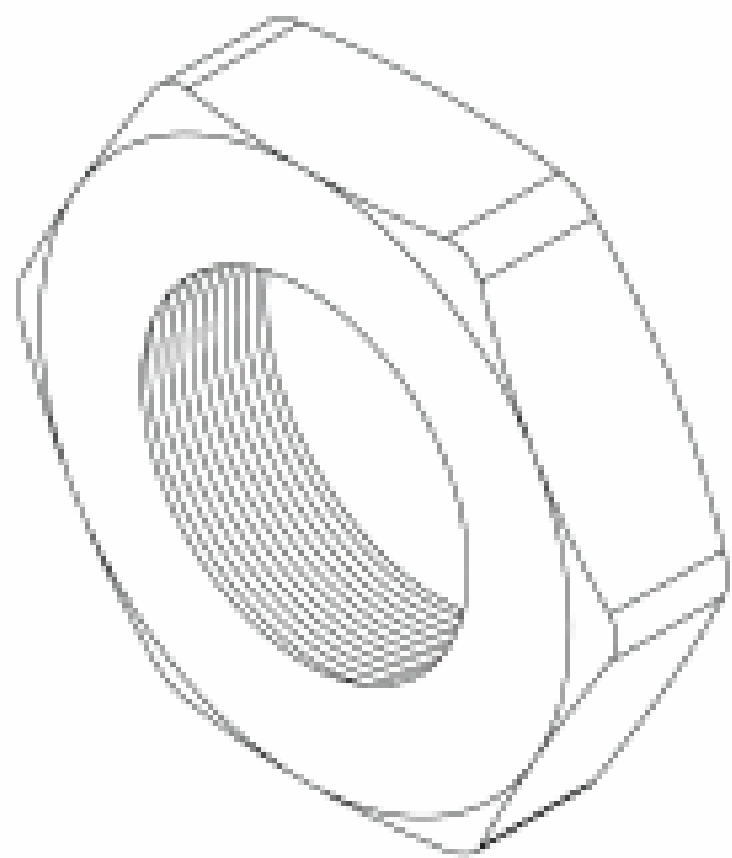

NOTES:

- 1) GENERAL DIMENSIONS DRAWINGS.
- 2) DIMENSIONS [ ] ARE IN INCHES.
- 3) DIMENSIONS NOTED ARE FOR REFERENCE ONLY.

Third angle projection

**SEALCON**

7374 S. EAGLE STREET  
 CENTENNIAL, CO 80112-4221 USA  
 TOLL FREE: 1-800-456-9012  
 PHONE: 303-699-1135  
 EMAIL: [info@SealconUSA.com](mailto:info@SealconUSA.com)  
 WEBSITE: [www.SealconUSA.com](http://www.SealconUSA.com)