

**HUMMEL AG**

Lise-Meitner-Straße 2

D-79211 Denzlingen

Telefon: +49 (0) 7666-91110-0

Telefax: +49 (0) 7666-91110-20

20.03.2012

## **UL94 vs. UL746C**

# **Flammability and standards**

- There is a lot of confusion about flammability ratings what they really are?
- UL 94 is a flammability standard for plastic materials, horizontal burning or vertical burning tests (HB V-2, V1, V-0)
- UL94-5V is test standard for the materials which are already classified in UL94 V-0, including both vertical and horizontal burning tests (UL94-5VA or UL94-5VB)
- UL746C is standard for polymeric materials used in electrical equipment, required by (UL50 Enclosures for electrical equipments)
- Glow wire ignition test assesses the fire behaviour of the material when heated glowing wire is applied (GWIT)

## UL 94 V0, V-1, V-2

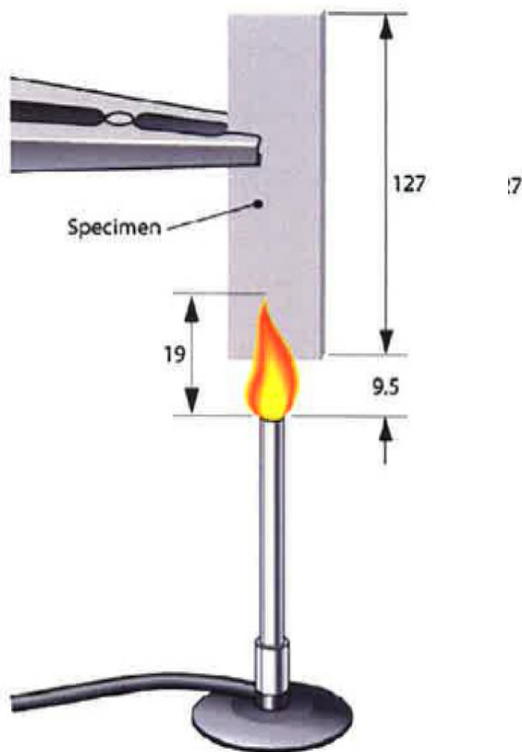

- Vertical burn test with 20mm flame applied for two 10sec intervals separated by the time it takes for flaming combustion to stop after the first application of the flame.
- Two sets of 5 specimen are tested.
- Burning and glowing times are measured, if flaming drips occur whether they ignite the cotton beneath or not, are the criterias for the classification V-0, V-1 and V-2

- HB- horizontal burn: slow burning on a horizontal specimen lowest rating (least flame retardant)
- V-2 vertical burn: burning stops within 30sec. Flaming drips are allowed
- V-1 vertical burn: burning stops within 30sec. No flaming drips are allowed
- V-0 vertical burn: burning stops within 10sec. No flaming drip are allowed

# UL 94 5V

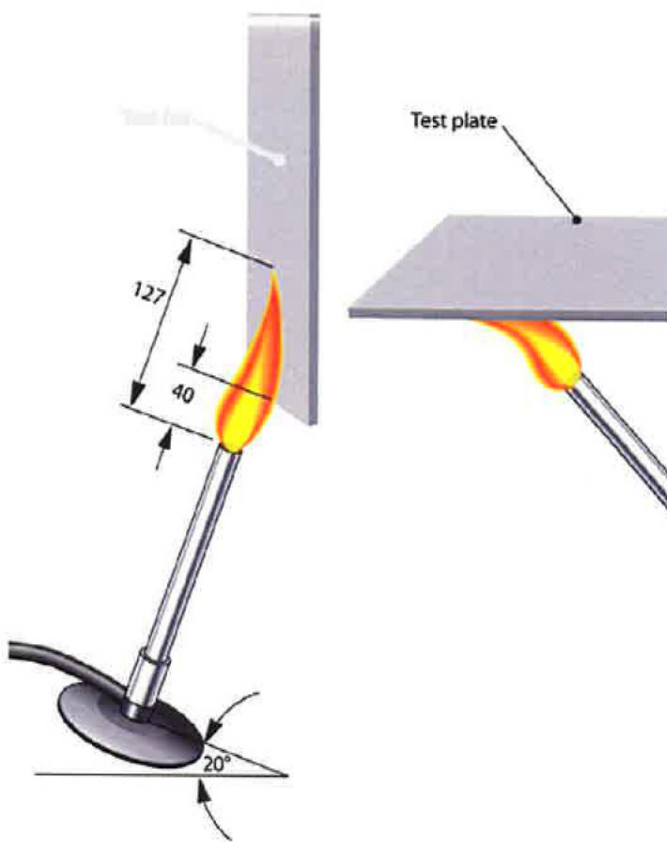

- Vertical burn test, with 127mm flame applied 5 times 5sec and removed for 5sec in between
- Burning and glowing times are measured
- No flaming drips which ignite the cotton beneath are allowed
- Plaques of specific size preferable with same thickness than testbars are tested with the same flame in horizontally
- Sets of 3 specimen are tested Tests are classified with two results:
- 5VB (surface burn) burning stops within 60sec., burn through is allowed (hole)
- 5VA (surface burn) there may not be burn through (a hole) in the specimen, this is the highest (most flame retardant) UL94 rating

## UL 746C

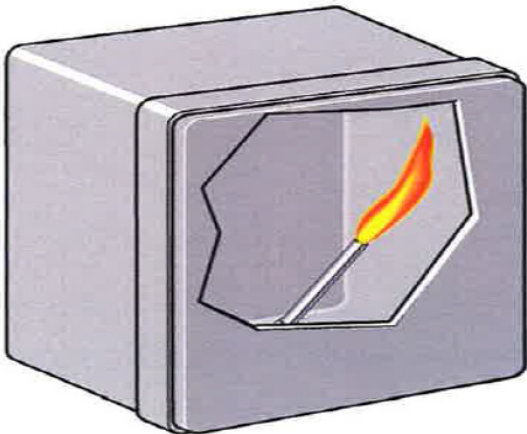

- Device burn test, inside of the equipment with 127mm (5inch) flame applied 5 times 5sec. removed for 5sec. in between
- 3 test samples, tested flame applied to the different location on each sample
- Burning shall not continue after 1 minute, no flaming drips are allowed which ignite the cotton beneath the test specimen
- The material shall not be destroyed in the area of the test flame to such an extent that the integrity of the part is affected with regard to containment of fire

If all the materials are classed as UL 94-5VA in molded parts, UL 746C flammability test are not required for the equipments